

This article was downloaded by:

On: 24 January 2011

Access details: *Access Details: Free Access*

Publisher *Taylor & Francis*

Informa Ltd Registered in England and Wales Registered Number: 1072954 Registered office: Mortimer House, 37-41 Mortimer Street, London W1T 3JH, UK



Journal of Macromolecular Science, Part A

Publication details, including instructions for authors and subscription information:

<http://www.informaworld.com/smpp/title~content=t713597274>

The Effect of Crosslinking on Toughness of Composite Ldpe/Silica

I. Chodák^a; I. Chorvath^a; S. Seidler^b; I. Janigova^a; H. J. Radusch^b

^a Polymer Institute Slovak Academy of Sciences, Bratislava, Slovak Republic ^b Technical University Carl Schorlemmer, Merseburg, Germany

To cite this Article Chodák, I. , Chorvath, I. , Seidler, S. , Janigova, I. and Radusch, H. J.(1994) 'The Effect of Crosslinking on Toughness of Composite Ldpe/Silica', Journal of Macromolecular Science, Part A, 31: 10, 1455 – 1467

To link to this Article: DOI: 10.1080/10601329409350103

URL: <http://dx.doi.org/10.1080/10601329409350103>

PLEASE SCROLL DOWN FOR ARTICLE

Full terms and conditions of use: <http://www.informaworld.com/terms-and-conditions-of-access.pdf>

This article may be used for research, teaching and private study purposes. Any substantial or systematic reproduction, re-distribution, re-selling, loan or sub-licensing, systematic supply or distribution in any form to anyone is expressly forbidden.

The publisher does not give any warranty express or implied or make any representation that the contents will be complete or accurate or up to date. The accuracy of any instructions, formulae and drug doses should be independently verified with primary sources. The publisher shall not be liable for any loss, actions, claims, proceedings, demand or costs or damages whatsoever or howsoever caused arising directly or indirectly in connection with or arising out of the use of this material.

THE EFFECT OF CROSSLINKING ON TOUGHNESS OF COMPOSITE LDPE/SILICA

I. CHODÁK and I. CHORVATH

Polymer Institute
Slovak Academy of Sciences
84236 Bratislava, Slovak Republic

S. SEIDLER

Technical University Carl Schorlemmer
Merseburg, Germany

I. JANIGOVA

Polymer Institute
Slovak Academy of Sciences
84236 Bratislava, Slovak Republic

H. J. RADUSCH

Technical University Carl Schorlemmer
Merseburg, Germany

ABSTRACT

The effect of crosslinking on the toughness of LDPE filled with two different grades of silica was investigated. An elastic plastic fracture mechanism based on the J integral has been used to evaluate the results of notch impact resistance. Crosslinking of the matrix in PE/silica composites leads to improved toughness when compared to uncrosslinked composites. The increase of toughness results mainly from an increase in the amount of plastic deformation and, consequently, higher ultimate deformation at fracture. A positive effect of crosslinking on the develop-

ment of plastic deformation was also demonstrated by SEM, showing that the fracture is entirely cohesive.

INTRODUCTION

Several important parameters can be calculated from the stress–strain curve of thermoplastics, e.g., Young's modulus, yield stress, tensile strength, etc. Besides these, the area under the curve is proportional to the energy necessary for fracture of the sample. This value is known as toughness W_p :

$$W_p = \int_0^{\epsilon_B} \sigma_B(\epsilon_B) d\epsilon \quad (1)$$

For brittle plastics, $W_p = \frac{1}{2}\sigma_B\epsilon_B$ is approximately valid, where σ_B and ϵ_B are the stress and strain at break, respectively. For ductile plastics the stress–strain curve is usually more complicated, and it is not possible to describe it by an applicable function.

The toughness of ductile plastics is usually one order of magnitude higher than that of brittle materials. The difference is probably caused by forced elasticity and plastic deformation if the stress is higher than the yield stress of ductile plastics. The presence of an inorganic particulate filler usually results in a change of the ductile nature of the fracture to a brittle one.

Toughness characterized by the values of impact resistance is affected to a great extent by inhomogeneities, i.e., by the presence of cracks and voids [1, 2]. Cracks and voids are modeled by introducing a notch into the specimen [3]. This method is called the notch impact resistance test. The notch can be considered as a crack with a well-characterized size. Its effect on fracture of the specimen should dominate when compared to the sum of the effects of all other defects. Thus, by introducing one dominant crack, the effect of small voids and inhomogeneities formed in the material during processing can be almost completely eliminated. The notch acts as a stress concentrator, and the energy consumed during fracture of the sample is equal to the energy of crack growth. When the notch impact resistance of composites with a thermoplastic matrix is investigated, a plastic part of deformation can participate extensively besides the elastic deformation. The routinely used methods for measuring the notch impact resistance (Charpy, IZOD) suffer from the fact that an exact description of the parameters of fracture of the materials is impossible. The values obtained are not the material's characteristics since they depend, besides other factors, on the geometry of the sample. Obviously, there is no possibility of distinguishing between plastic and elastic deformation during the initiation and propagation of fracture across the specimen. Differentiation can be made by using fracture mechanics; the deformation fracture parameters can be determined either from linear fracture mechanics in the case of linear elastic behavior of the material or from elastic plastic fracture mechanics if a substantial portion of plastic deformation takes part [4]. Several possibilities exist for application of elastic plastic fracture mechanics, one of which is a characterization by the J integral. The measurement of notch impact resistance during a short time period results in a value for the energy consumed for fracture of the material. This energy is the sum of elastic and plastic parts of deformation and of the energy of crack propagation.

Several models are used to express the J integral [5-7]. These differ in the mode of accounting for both the geometry of the sample and the ratio of elastic to elastic plastic deformation, considering also other parameters, e.g., the kinetics of energy dissipation. This procedure, together with a proper experimental device, enables a more exact investigation of changes of notch impact resistance than do simple methods based on the measurement of total fracture energy.

Toughness of materials is affected significantly by the presence of filler [8]. Generally, toughness decreases with an increasing amount of filler. Various procedures for the modification of either the filler or the matrix are used to increase the toughness of filled plastics [9-11]. A combination of effects of the presence of a filler and a chemical modification of the LDPE matrix by radical processes initiated by decomposition of peroxide is investigated in this paper.

EXPERIMENTAL

The matrix of LDPE (Bralen RA-2-19, MFI = 2.0 g/10 min) was filled with two types of silica [Komsil (Kovohutě Mníšek, Czechia) and Ultrasil (Degussa, Germany)] which differ in their surface areas (Ultrasil, 139 m²/g; Komsil, 21 m²/g). Both fillers are characterized in detail in Reference 12.

The samples were mixed in the mixing chamber of a Brabender Plastograph internal mixer at 135°C for 5 minutes. Crosslinking of the matrix was initiated by 2,5-dimethyl-2,5-bis(*t*-butyl peroxy)hexyne-3 (Luperox 130, Luperox GmbH), 0.8 wt% related to PE content. The crosslinking was carried out in a press at 180°C for 20 minutes.

Notch impact resistance was measured at -20°C using a Charpy impact tester PSW 0.4 under the following conditions: the hammer speed was 1.5 m/s, the weight of the hammer was 0.955 kg, and the arm length was 0.22 m. The size of a specimen was 80 × 10 × 4 mm, and the distance between the stand points was 40 mm. A notch of 2 mm depth was made by a sharp cut with a blade.

An example of the dependence of load on deformation is given in Fig. 1, where F_M is the maximal force, D_M is the maximal deformation, F_G and D_G are the

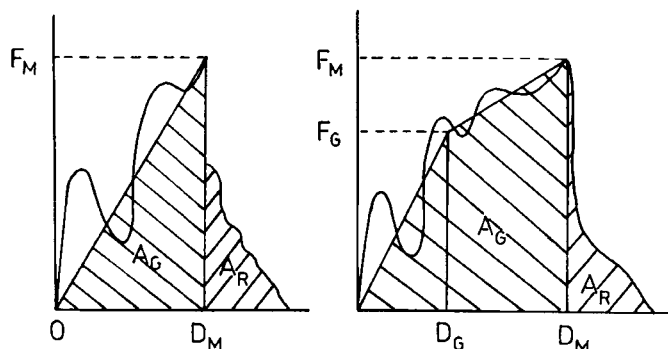

FIG. 1. Typical stress-strain dependence of samples with elastic and elastoplastic fracture.

force and deformation at the point of transition from the elastic to the elastoplastic region, and A_G is the energy of crack propagation. The nature of the fracture can be determined by a comparison of D_M and D_G values: the fracture is elastic if $D_M \approx D_G$, the fracture is elastoplastic if $D_M > D_G$.

Measurement of impact resistance was carried out at -60 , -40 , -20 , 0 , and 20°C using a simple device based on a falling weight method (Fig. 2). Weights of 20.5, 50.8, and 101.8 g were used; the height of the fall was 10, 20, 30, or 40 cm. The impact resistance was calculated from the weight and height used when the specimen was broken. The thickness of specimens was 0.2 mm, the width was 7 mm, and the distance between the stand points was 22 mm. The samples were kept in a bath of ethanol cooled by solid CO_2 down to a desired temperature within $\pm 0.5^\circ\text{C}$. The reason for using different methods was that we wanted to investigate the impact behavior in a broad temperature range. However, at room temperature (and partially also as 0°C), the samples were impossible to break if Charpy-type specimens were used. Therefore thinner samples were used for measurements of temperature dependence. These values have only been considered within this particular set of values and were not compared with other data obtained by the Charpy method.

Ten measurements were carried out for evaluating one experimental point. The fracture surfaces of selected samples were observed using a scanning electron microscope (Tesla BS 300). Since the surface of particles after fracture was covered by a layer of polymer, the fracture surface was etched by cold plasma for either 20 seconds or for 5 minutes at 1000 V at a current intensity of 30 mA and at a ratio of supplied to effective power of 5:1.

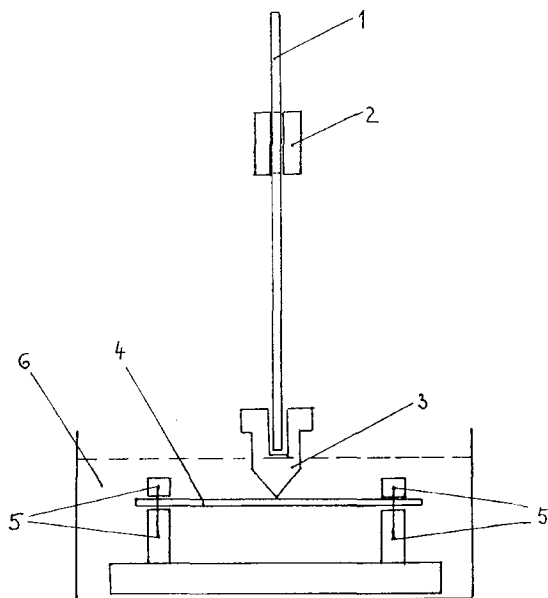

FIG. 2. Scheme of a falling weight device. Iron rod (1), weight (2), ram (3), sample (4), sample holders (5), cooling bath (6).

RESULTS AND DISCUSSION

According to literature data [13, 14], the J integral as proposed by Sumpter and Turner [5] is

$$J = \Omega_E A_E / B(W - a) + \Omega_P A_P (W - a_{ef}) / B(W - a)^2 \quad (2)$$

It is most appropriate for composites with a thermoplastic matrix. The equation is valid for $0.2 < a/W < 1$. A_E and A_P are the elastic and plastic energies, respectively, a is the depth of the notch, a_{ef} is the effective size of the notch in the direction of crack propagation from the fracture surface as determined by optical microscopy after breaking the specimen at the temperature of liquid nitrogen, and Ω_E and Ω_P are correction functions for the geometry of the sample. The results are independent of specimen dimensions if the whole experimental procedure is properly designed [15].

The dependence of the J integral on the content of Ultrasil or Komsil is shown in Fig. 3. The polyethylene matrix is of a ductile nature. The addition of a filler results in a decrease of the toughness, demonstrated by a decrease of the J integral value. This fact corresponds with the known effect that the presence of a filler leads to increased stiffness and lower deformability [11]. The filler acts as a stress concentrator and, at the same time, it negatively affects the mobility of macromolecules close to the filler surface. The observed differences in the effects of different fillers can be ascribed to better interaction between polyethylene and particles of Ultrasil than those of Komsil [16, 17] as a result of the larger specific surface of Ultrasil. Higher values of the J integral of composites with Ultrasil can thus be explained as well.

Crosslinking of a filled polyethylene leads to an increase of J integral values when compared to uncrosslinked polymer, as shown in Fig. 4. A maximum is observed on the plot of J integral vs volume portion of filler at about 7 vol% of Ultrasil. An increase in toughness can be caused by several factors: formation of a more resistant morphology (smaller spherulites, lower crystalline portion), higher molecular weight of the matrix, and modified properties of the interphase. Poly-

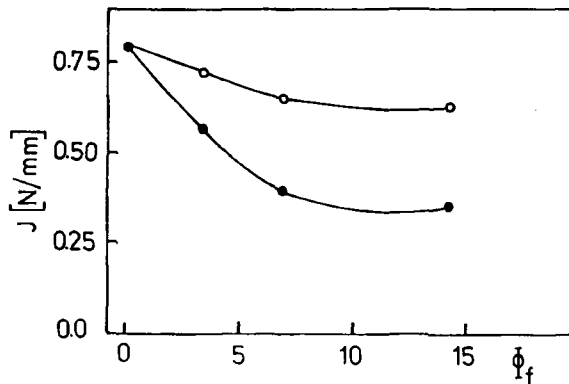

FIG. 3. The dependence of the J integral on the volume portion of filler in composites PE/Ultrasil (\circ) and PE/Komsil (\bullet).

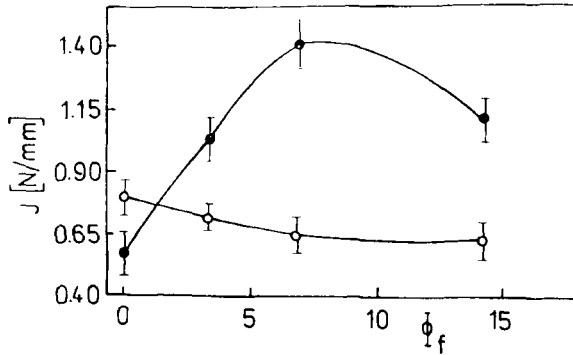

FIG. 4. The dependence of the J integral of uncrosslinked (O) and crosslinked (X) composite PE/Ultrasil on filler content (vol%).

mer-filler interaction may be influenced as well. All the above-mentioned factors may influence local deformation at the tip of the notch, which results in an increase in the energy needed for crack growth. With an increased amount of filler, immobilization of polymer chains is enhanced and the positive effect of crosslinking is partially eliminated.

The particles tend to form agglomerates at higher filler content. The stress is concentrated in their vicinity, and the formation and growth of cracks becomes easier. The parallel effects of filler and crosslinking result in the appearance of a maximum in the dependence (Fig. 4).

The presence of crosslinks can somehow contribute to the occurrence of plastic deformation in microvolumes. Higher values of the J integral are connected with a higher proportion of plastic deformation in the overall deformation. The nature of fracture is affected by the concentration and specific surface of the filler and by crosslinking, as is obvious from Tables 1 and 2. The fracture of polyethylene samples filled with Komsil is entirely elastic (Table 2); elastoplastic fracture was observed with composites filled with 3.4 and 6.9 vol% Ultrasil (Table 1). Polyethylene

TABLE 1. Maximal Deformation at Fracture (D_M), Deformation at Transition from Elastic to Elastoplastic Region (D_G), and Nature of the Fracture (F) vs Ultrasil Content (ϕ) for PE and PE Crosslinked with Luperox 130, 0.83%, Related to PE Content

ϕ , vol%	Uncrosslinked PE			Crosslinked PE		
	D_M , mm	D_G , mm	F^a	D_M , mm	D_G , mm	F^a
0	0.54	0.52	e	0.35	0.32	e
3.4	0.52	0.37	ep	0.67	0.49	ep
6.9	0.46	0.35	ep	0.67	0.52	ep
14.2	0.38	0.38	e	0.55	0.47	ep

^ae = elastic fracture, ep = elastoplastic fracture.

TABLE 2. Maximal Deformation at Fracture (D_M), Deformation at Transition from Elastic to Elastoplastic Region (D_G), and Nature of the Fracture (F) on Volume-% of Komsil (ϕ)

ϕ , vol%	D_M , mm	D_G , mm	F
0	0.54	0.52	e
2.95	0.43	0.39	e
6.03	0.31	0.31	e
12.6	0.28	0.28	e

without filler or filled with 14.2 vol% Ultrasil is broken by elastic fracture. Obviously, the presence of filler in the proper concentration can lead to an increase in the amount of plastic deformation of the material.

The effect of crosslinking consists not only in affecting the mode of failure but also in enhancing the plastic deformation of Ultrasil-filled samples. This fact corresponds to published results describing the effect of crosslinking on the value of elongation at break of composites [11].

Figure 5 shows a decrease of maximal deformation of the sample with increasing filler content. The decrease is less pronounced with Ultrasil; with 14.2 vol% filler the deformation is two-thirds of the value of polyethylene. With Komsil a drop to 50% of the original value was observed. When the average interparticle distance decreases due to increasing filler content, deformability of the matrix also decreases, corresponding to the restrictive effect of filler particles. This phenomenon is demonstrated in Table 1: the fracture of polyethylene filled with 14.2 vol% Ultrasil is brittle, and the mode of fracture is elastic, unlike samples with a lower filler content where elastoplastic behavior dominates.

The dependence of D_M vs filler content for composites crosslinked with 0.83 vol% Luperox 130 (related to polyethylene content) and filled with Ultrasil is shown

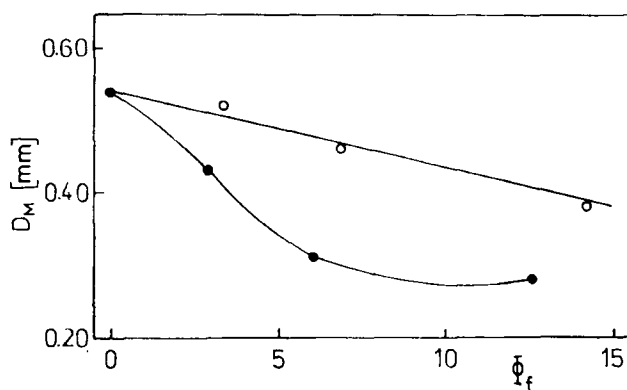

FIG. 5. The dependence of maximal deformation of composites PE/Ultrasil (○) and PE/Komsil (●) on volume portion of filler.

in Fig. 6. The dependence goes through a maximum, similar to a plot of the J integral vs filler content. The cracks formed around the filler can manifest themselves as weak sites in the composite. On the other hand, if the cracks have the proper shape and size they may affect toughness positively, e.g., due to slowing down the rate of growth of cracks of larger than critical size, or because of the formation of small cracks on the polymer-filler interface connected with a certain consumption of energy. The properties of both the matrix and interphase are changed as a result of crosslinking. A most important feature is increased tear resistance [18]. In any case, increasing the filler content results in a higher degree of restriction of macromolecular motion in the polymer matrix.

An important amount of plastic deformation was also observed when 14.3 vol% Ultrasil was present in the sample, as is seen in Table 1. This is an explanation for the higher deflection of a crosslinked sample compared to that for an uncrosslinked one where the fracture is brittle.

The temperature dependence of impact resistance of unfilled and filled polyethylene (PE), as investigated by the falling weight method, is shown in Fig. 7. Increasing the filler content results in lower impact resistance in the whole temperature range. Impact resistance of filled samples is marginally affected by temperature, unlike unfilled PE. The effect is probably caused by the restrictive influence of filler particles on matrix deformation, which is significant enough to eliminate the effect of temperature on deformability of the matrix. A distinct minimum is observed in a plot of impact resistance vs temperature at -40°C for both crosslinked (Fig. 8) and uncrosslinked PE. We cannot explain the existence of this minimum, but it may be connected with some changes of mobility of macromolecules with temperature.

Crosslinking results in an increase of impact resistance of PE as well as of PE filled with 3.4 or 26.4 vol% Ultrasil when compared to uncrosslinked samples (Fig. 8). With increasing filler content, the values of impact resistance diminish, similar to uncrosslinked samples. Unlike uncrosslinked samples, impact resistance values are positively affected by an increase of temperature. It is concluded that filler has a smaller effect on the decrease of deformability of crosslinked samples than of

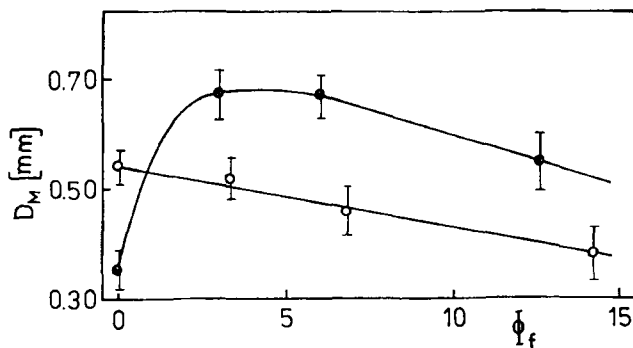

FIG. 6. The dependence of maximal deformation of uncrosslinked (\circ) and crosslinked (\otimes) composite PE/Ultrasil on volume portion of filler.

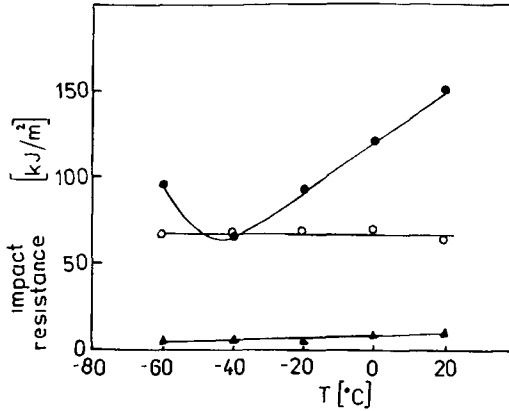

FIG. 7. The plot of impact resistance vs temperature for samples of PE with 0 (●), 3.4 (○), and 26.4 (▲) vol% Ultrasil.

uncrosslinked material. Therefore, a change of temperature has a more pronounced effect in crosslinked material.

Additional results have been obtained from the observation of fracture surfaces by SEM. Figures 9 and 10 demonstrate that the fracture of notched specimens is cohesive, i.e., the crack grows through the matrix in both crosslinked and uncrosslinked samples. The growth of the crack is directly influenced by large aggregates. In the vicinity of their surface, plastic deformation is much less pronounced, as documented in Fig. 10. In the upper part of Fig. 9(a), bulk aggregate covered with the polymer layer is seen and plastic deformation on its surface is clearly different from the rest of the sample surface. The contribution of crosslinking to an increase in plastic deformation is confirmed by comparison of Figs. 9 and 10, as expected from the results in Table. 1.

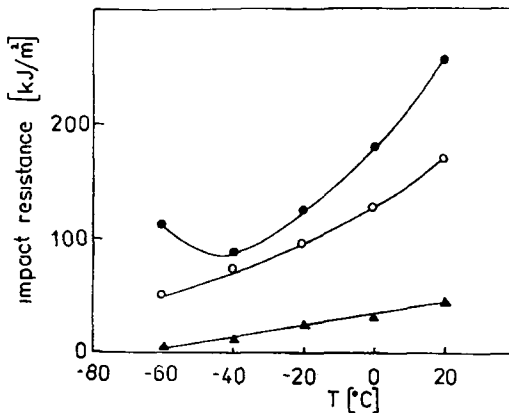

FIG. 8. The dependence of impact strength on temperature for crosslinked PE with 0 (●), 3.4 (○), and 26.4 (▲) vol% Ultrasil.

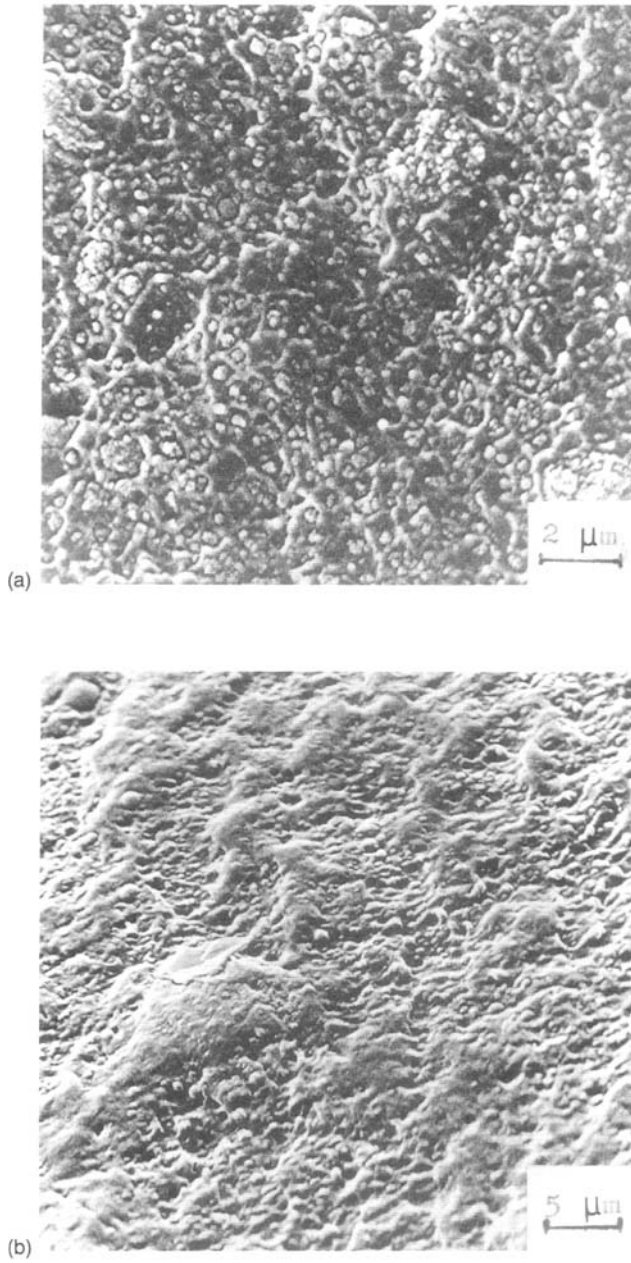

FIG. 9. The fracture surface of PE filled with 14.2 vol% Ultrasil (a) or 12.6 vol% Komsil (b).

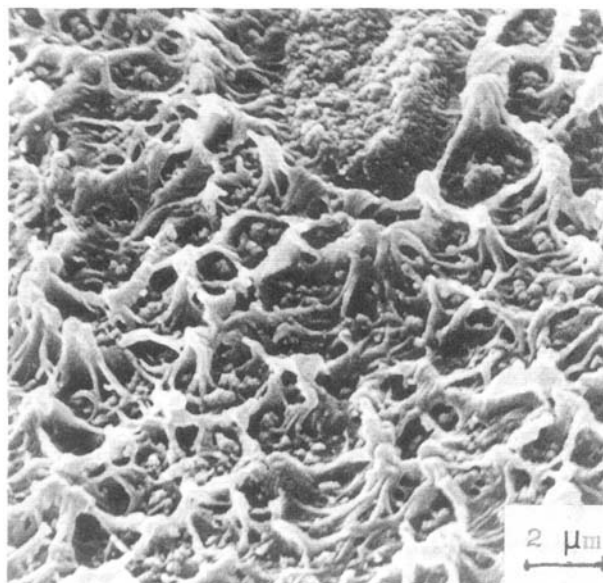

FIG. 10. Fracture surface of crosslinked composite PE with 12.6 vol% Komsil.

Since the fracture is cohesive in all cases, filler particles are not visible directly in Figs. 9 and 10. The filler surface can be observed after the surface polymer layer is removed by etching with cold plasma. The etched areas are seen in Figs. 11(a) and 11(b). When the fracture surfaces are compared, it is obvious that the effect of the two fillers used is almost the same. At the surfaces with both Ultrasil and Komsil, the filler particles strongly bound to matrix are seen in the middle of the fracture area (Fig. 11a). On the other hand, at the end of the fracture area, voids between filler surface and matrix are visible (Fig. 11b).

Dewetting in a much larger range is observed at the fracture surfaces of crosslinked samples (Fig. 12). Since the nature of these samples is different than that of uncrosslinked materials, it can be expected that the different structures were not formed during processing but during breaking of the specimens, i.e., dewetting occurs during fracture. This is fully consistent with the hypothesis that certain additional energy is consumed due to formation of small voids which do not cause a catastrophic crack. Since deformability of uncrosslinked materials is lower than that of crosslinked composites [18], local deformation at break is not high enough to result in dewetting. The notch advances through the material without any significant observable changes near the fracture level. On the other hand, significant deformation can occur in crosslinked samples so that local deformation is higher than the deformability of the interphase. Therefore, dewetting takes place, leading to the formation of small voids of noncatastrophic size.

According to results of impact resistance, it is concluded that:

The presence of filler leads to a decrease of toughness resulting from the formation of inhomogeneities.

The filler leads to a decrease of deformation due to lower mobility of macromolecules.

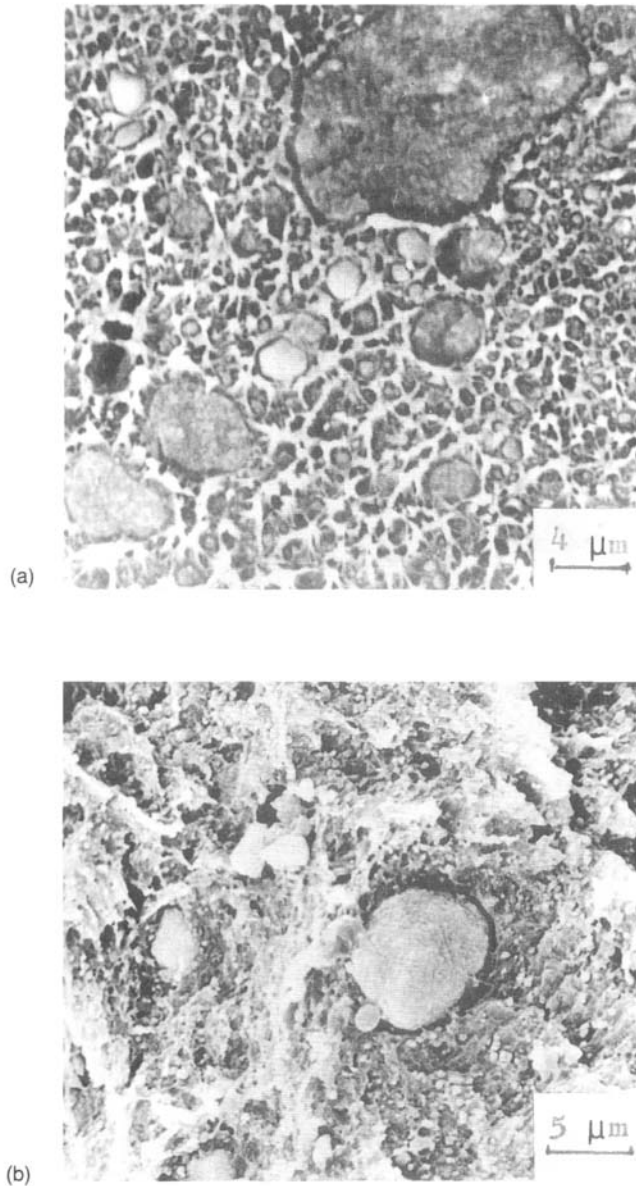

FIG. 11. Fracture surface of PE with 14.2 vol% Ultrasil (a), or with 12.6 vol% Komsil (b), etched with plasma for 20 seconds.

Crosslinking results in an increase of toughness due to formation of crosslinks in the polymer matrix.

Crosslinking leads to a rise of deformation, mainly because of a larger amount of plastic deformation.

SEM experiments showed that fracture is cohesive. The positive effect of crosslinking was demonstrated by the development of plastic deformation.

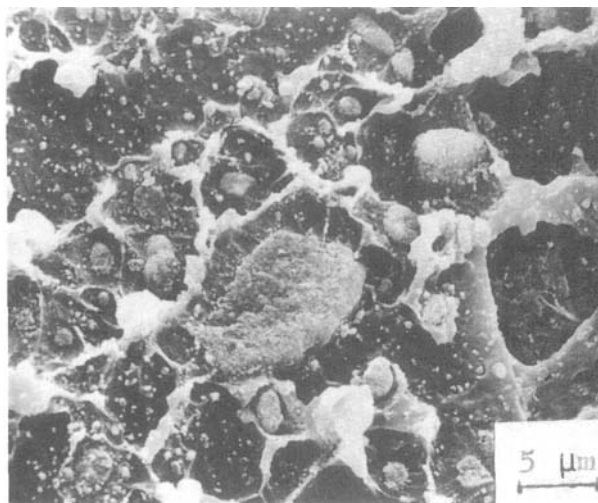

FIG. 12. Fracture surface of crosslinked PE filled with 14.2 vol% Ultrasil, etched with plasma for 5 minutes.

REFERENCES

- [1] P. L. Fernando, *Polym. Eng. Sci.*, **28**, 806 (1988).
- [2] K. L. De Vries and L. E. Hornberger, *Polym. Degrad. Stab.*, **24**, 213 (1989).
- [3] I. Narisawa and M. T. Takemori, *Polym. Eng. Sci.*, **29**, 671 (1989).
- [4] W. Grellmann, S. Seidler, and E. Nezbedova, *Plasty Kauc.*, **27**, 236 (1990).
- [5] J. D. G. Sumpter and C. E. Turner, *Crack and Fracture* (ASTM STP 601), 1976, pp. 3-18.
- [6] J. G. Merkle and H. T. Corten, *J. Press. Vessel Technol.*, **96**, 286 (1974).
- [7] T. Kanazawa, D. Machida, M. Onozuka, and S. Kaned, *Rep. Univ. Tokyo*, *Hw x-779-75*.
- [8] G. Levita and A. Marchetti, *Polym. Compos.*, **10**, 39 (1989).
- [9] V. P. Chacko, F. E. Karasz, and R. J. Farris, *Polym. Eng. Sci.*, **22**, 968 (1982).
- [10] D. Faulkner, *J. Appl. Polym. Sci.*, **36**, 467 (1988).
- [11] L. Chen, Y. Mai, and B. Cotterel, *Polym. Eng. Sci.*, **29**, 505 (1989).
- [12] I. Chodák, I. Chorváth, I. Novák, and K. Csomorová, *Eur. Polym. J.*, **28**, 107 (1992).
- [13] H. Hoffmann, H. P. Schlumpf, W. Grellmann, and H. Martin, *Plaste Kautsch.*, **32**, 107 (1985).
- [14] H. Hoffmann, W. Grellmann, and V. Zilvar, *Polymer Composites*, Walter de Gruyter Co., Berlin, 1986.
- [15] H. Blumenauer and G. Push, *Technische Bruchmechanik*, VEB Deutscher Verlag f. Grundstoffindustrie, Leipzig, 1982, p. 119.
- [16] B. Pukánszky and B. Turcsányi, *Interfaces in Polymer, Ceramics, and Metal Matrix Composites, Proceedings of the ICCI, II*, Cleveland, Ohio, 1988.
- [17] I. Chorváth, I. Chodák, I. Novák, and H.-J. Radosch, *7th IUPAC Conference on Modified Polymers*, Bratislava, 1988, p. A31.
- [18] I. Chodák, *Makromol. Chem., Macromol. Symp.*, **41**, 229 (1991).